



Report Type:

Residential

Job Name: 123 Main St, Orlando, FL 25464

COMPANY INFORMATION

John Smith Roofing

John Smith

789-456-123

jsmithroofing@myemail.com

TABLE OF CONTENT

- Cover Page
- 3D View
- Panel Cutlist
- Roof Diagram
- Accessories
- Area by Section
- Pitch Diagram

Measurements by **Skyview Estimator**

3D VIEW

Job Name: 123 Main St, Orlando, FL 25464

Standing Seam, Width: 18", Gauge: 24

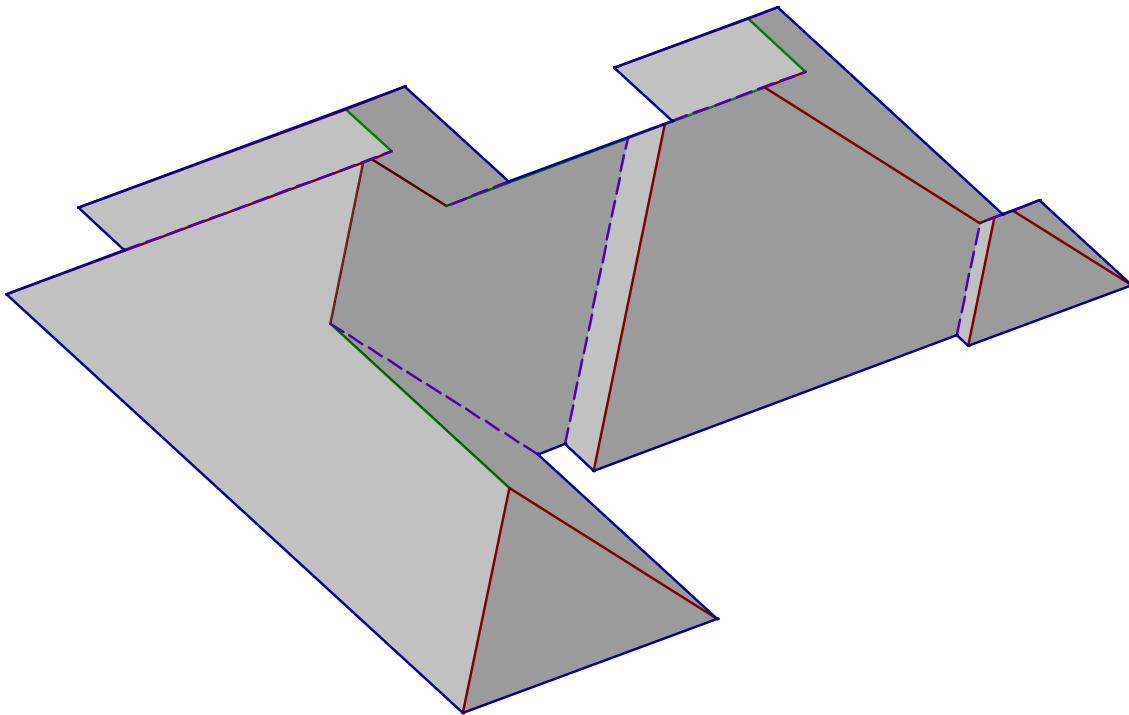

PANEL CUTLIST

Job Name: 123 Main St, Orlando, FL 25464

Standing Seam, Width: 18", Gauge: 24

Qty	Length	Qty	Length	Qty	Length
2	31' 10"	3	12' 10"		
1	30' 10"	10	12' 8"		
16	28' 10"	5	11' 10"		
2	27' 8"	6	10' 10"		
3	26' 10"	7	10' 8"		
4	25' 8"	14	9' 10"		
2	24' 10"	7	8' 10"		
3	23' 10"	2	8' 8"		
2	23' 8"	4	7' 10"		
4	22' 10"	15	6' 10"		
6	21' 10"	4	6' 8"		
5	20' 10"	8	5' 10"		
5	19' 10"	6	4' 10"		
29	18' 10"	2	4' 8"		
1	17' 10"	11	3' 10"		
1	17' 8"	12	2' 10"		
10	16' 10"	1	2' 8"		
7	15' 10"	3	1' 10"		
1	15' 8"	3	0' 10"		
12	13' 10"				

ROOF AREA

7,053 Square Feet

ROOF DIAGRAM

Job Name: 123 Main St, Orlando, FL 25464

Standing Seam, Width: 18", Gauge: 24

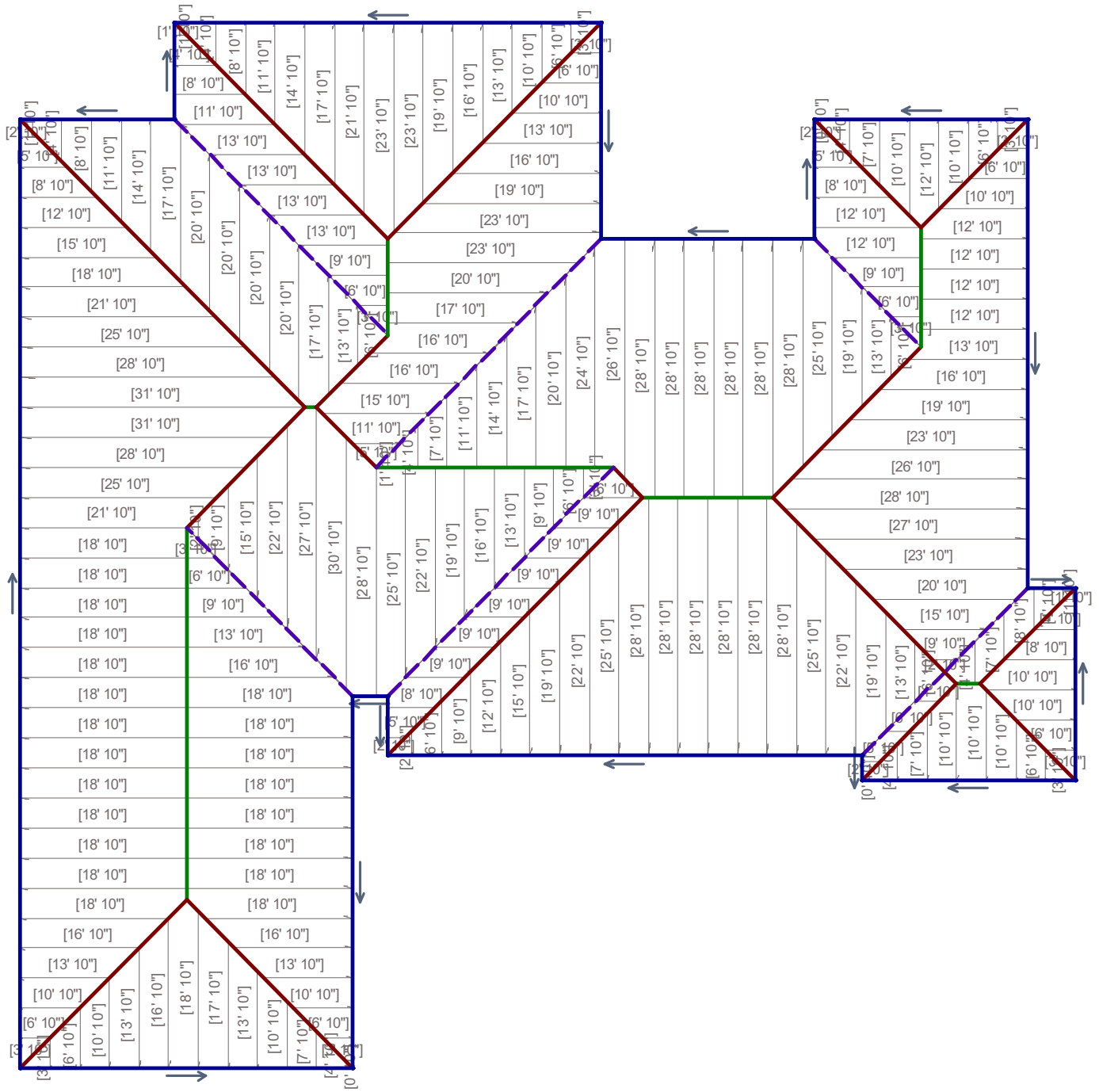

ACCESSORIES

Job Name: 123 Main St, Orlando, FL 25464

Standing Seam, Width: 18", Gauge: 24

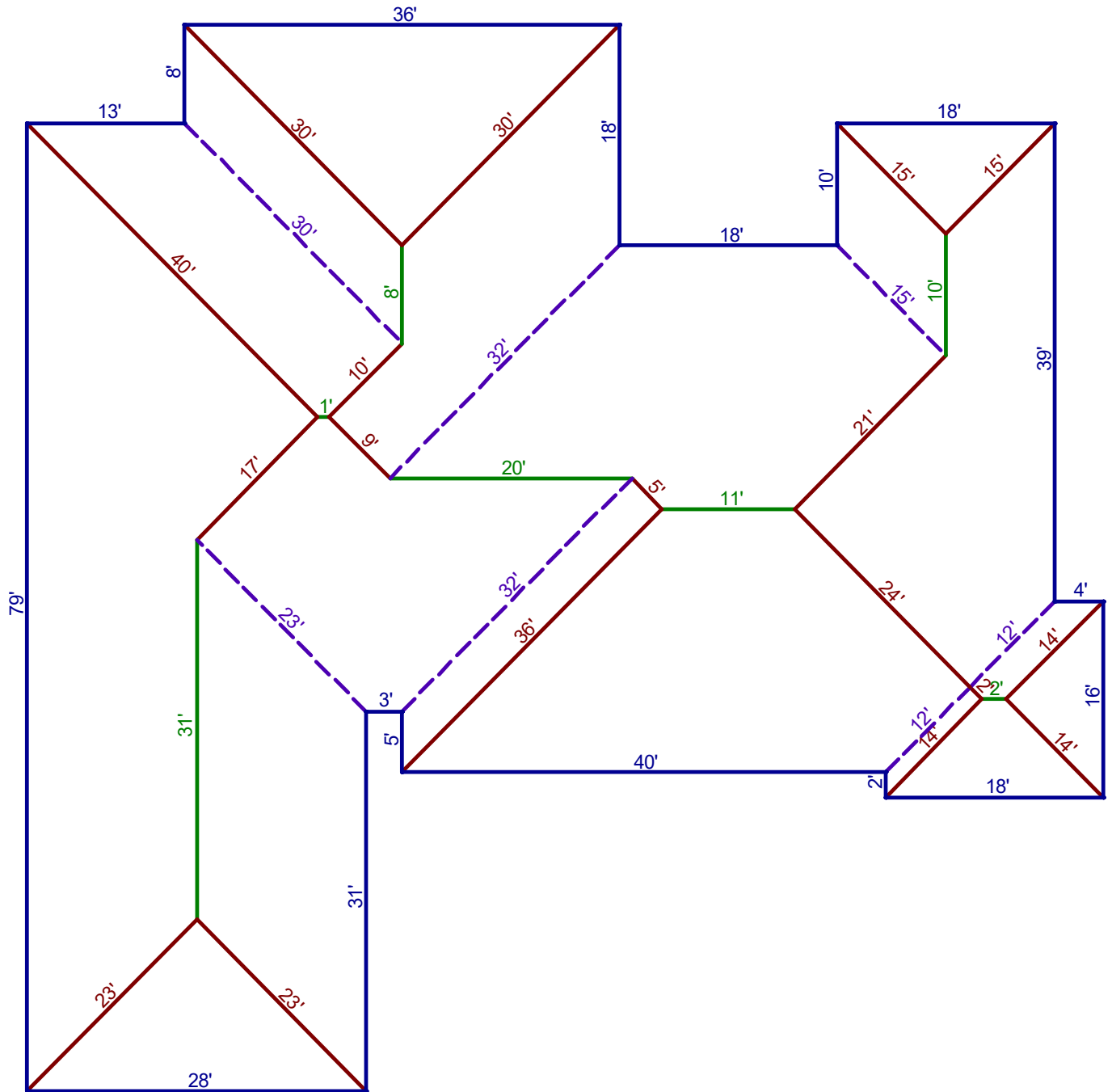

Eaves ----- 386.00 LF

Valleys ----- 152.66 LF

Headwall Flashing -- 0.00 LF

Ridges ----- 83.00 LF

Step Flashing -- 0.00 LF

Hips ----- 333.22 LF

Rakes ----- 0.00 LF

AREA BY SECTION

Job Name: 123 Main St, Orlando, FL 25464

Standing Seam, Width: 18", Gauge: 24

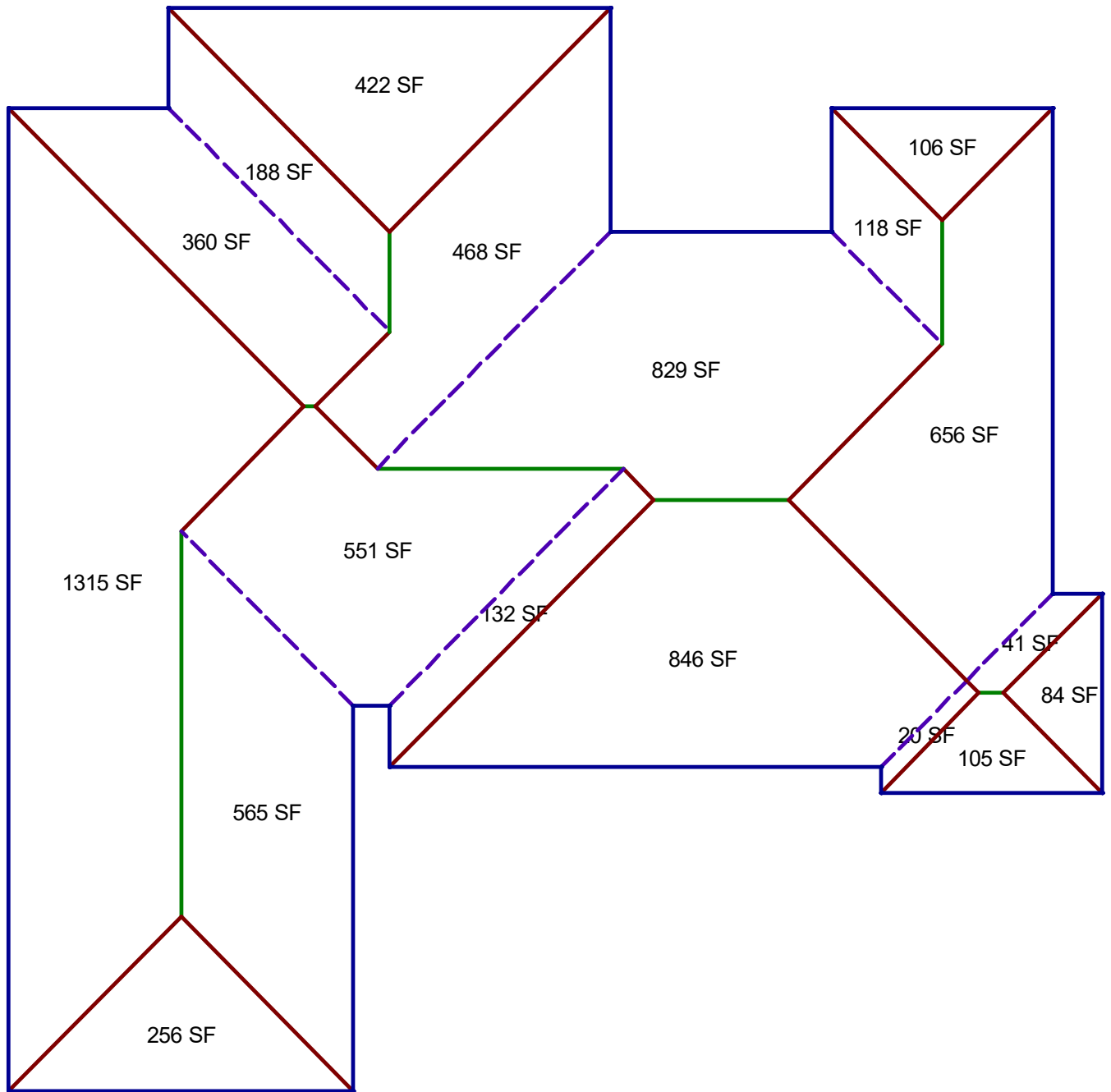

Total Roof Area

7053 SF

PITCH DIAGRAM

Job Name: 123 Main St, Orlando, FL 25464

Standing Seam, Width: 18", Gauge: 24

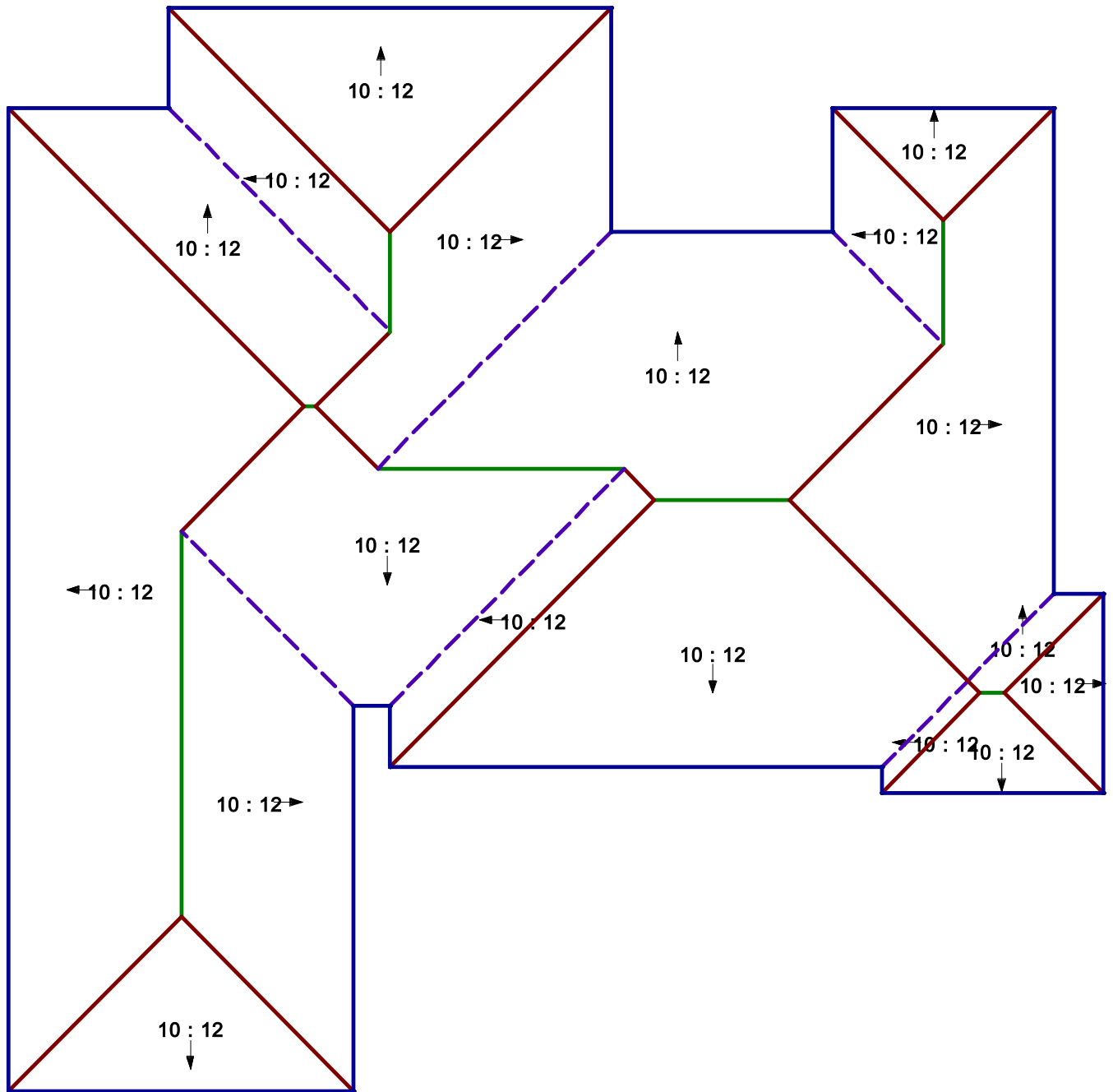

Roof Pitch

10 : 12